



ZANOTTI Spa
Via M.L. King, 30
46020 - Pegognaga (MN) - ITALY
Tel. +39 0376 5551
Fax +39 0376 536554
info@zanotti.com

Tarjeta técnica máquina

Versión 1.48

Modelo:

MSB530EB13XX

Categoría:

Uniblock SB

Datos técnicos

Características	U.M.	Valor
Temperatura trabajo	°C	+10 ÷ -5
Arranque		Directo
Voltaje	Volt-Ph-Hz	400/3N~/50
Absorción nominal	kW*	3,40
Absorción nominal	Amp*	7,90
Corriente de arranque	Amp	69,0
Corriente máxima	Amp	16,2
Refrigerante		R134a
	GWP	1430
Desescarche		Gas caliente
Masa	Kg	151

Compresor

Tipo		Hermético
Potencia nominal	kW	3,7

Condensador

Volumen de aire	m³/h	3200
-----------------	------	------

Evaporador

Volumen de aire	m³/h	3450
Proyección aire	m**	10

Categoría PED		1
---------------	--	---

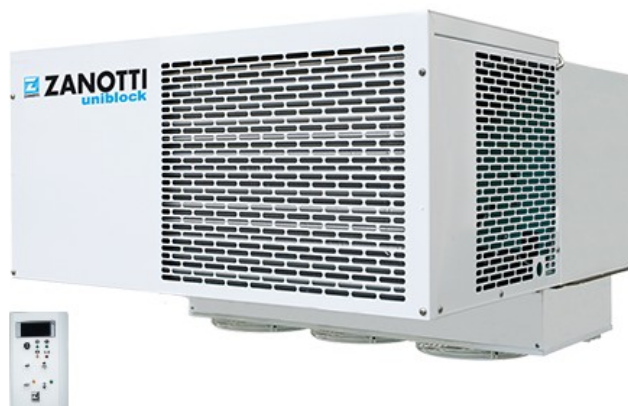

Datos de la energía

Tc °C	Ta °C	P watt	P Kcal/h	V100 m³	V80 m³	V60 m³
	20	8004	6883	109	99	90
	25	7632	6564	102	93	85
10	30	7197	6189	95	86	79
	35	6727	5785	87	79	72
	40	6252	5377	79	72	66
	20	6791	5840	88	80	73
	25	6419	5520	82	75	68
5	30	6037	5192	76	69	63
	35	5647	4856	69	63	57
	40	5250	4515	63	57	52
	20	5698	4900	70	64	58
	25	5217	4487	63	57	52
0	30	4871	4189	57	52	47
	35	4578	3937	52	47	43
	40	4254	3658	47	43	39
	20	4478	3851	51	46	42
	25	4137	3558	45	41	37
-5	30	3819	3284	40	36	33
	35	3523	3030	36	33	30
	40	3252	2797	31	28	26

* En funcionamiento: 0 ÷ +30°C

** Utilizar como mera indicación. La proyección del aire depende de numerosos factores: altura de la cámara, almacenamiento del producto, posición del evap.etc.

Tc: Temperatura cámara fría - TA: Temperatura externa.

P: Capacidad refrigerante - V: Volumen del cámara de Reccomanded

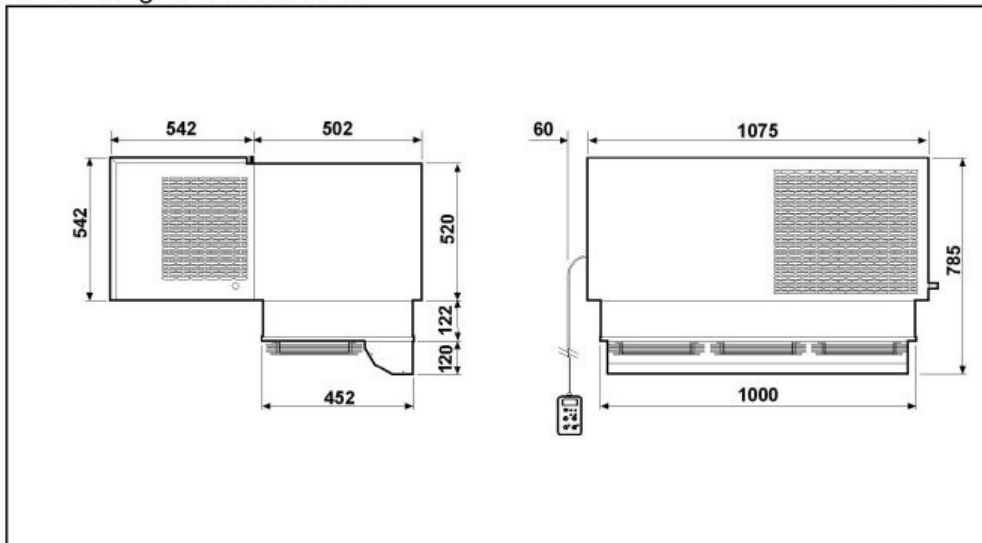

Schema di montaggio - Mounting scheme - Schema de montage
Montageschema - Esquema de montaje

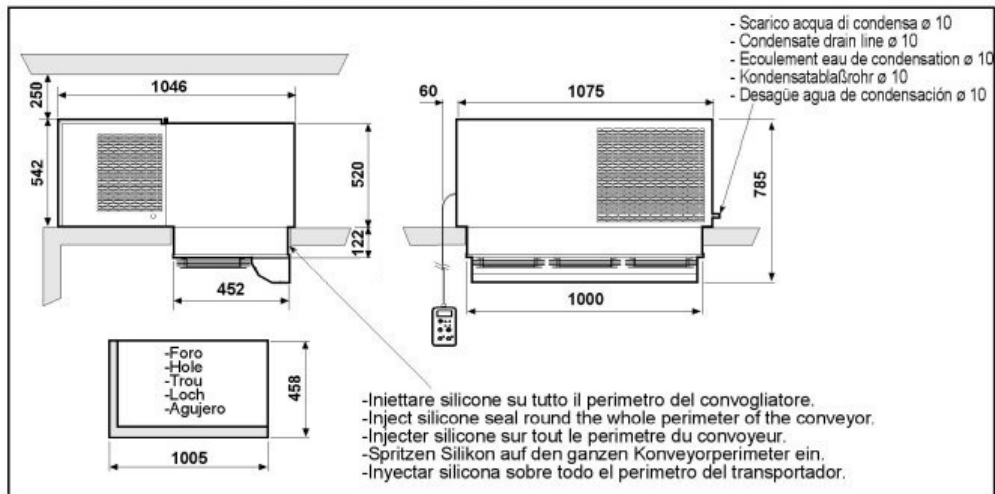

- * Raccomandazioni in sede di installazione e per il controllo fornite sul manuale di installazione
- * To be advised at time of order for factory installation and operating instructions
- * Recommendations au moments d'installations et pour le contrôle fournis sur le manuel d'installation
- * Empfehlungen für die Installationsphase und zur Kontrolle, die im Handbuch zur Installation enthalten sind
- * Por cuanto respecta a recomendaciones de instalación y control ver manual de instalación

Massa e misure imballi - Packing mass and dimensions - Masse et dimensions emballages
Verpackungsmasse und-abmessungen - Masa y medidas del embalaje

